



 **Vitap**  
Create Smarter



Machines for  
processing  
**Wood**

Machines for  
processing  
**Advanced  
Materials**

Multimedia catalog

scan the QR code



touch the QR code



or

# Automation and CNC Boring Center K2 2.0

*...manufactured in Italy*



  
edition 2021

- **Catalogo multimediale** potete scannerizzare con il vostro telefono il codice QR o potete cliccare sul codice QR.
- **Multimedia catalog** you can scan the QR code with your phone or you can click on the QR code.
- **Catalogue multimédia** vous pouvez scanner le code QR avec votre téléphone où vous pouvez cliquer sur le code QR.
- **Catalogo multimedia** Podeis escanear con vuestro smartphone el código QR. Podeis hacer clic en el código QR.



# Welcome to the Vitap experience ... 2020 evolution of the species

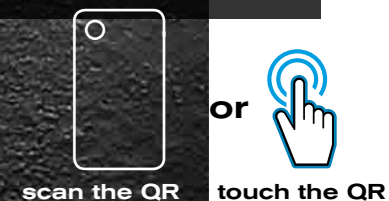

- Whale skeleton
- Squelette de baleine



- Plexiglass processing



- Really flexible...



- Corian and solid surfaces



*...manufactured in Italy*



- 🇮🇹 Benvenuti nella "RIVOLUZIONE BAR NESTING" con tutti i vantaggi della lavorazione nesting classica ma senza più limiti nelle forature orizzontali. Per passare da alte produzioni a "PRODUZIONI JUST IN TIME" è oggi giorno rispondere alle continue tendenze del mercato.
- 🇬🇧 Welcome to the "BAR NESTING REVOLUTION", all the nesting advantages and without limits in the execution of horizontal holes. Switching from high production to cost reduction in order to respond to a continuing changing market.
- 🇫🇷 Bienvenue dans la "REVOLUTION BAR NESTING", tous les avantages du nesting et pas de limites dans l'exécution des perçages horizontaux. Pour passer de la production de lots à le "JUST IN TIME", il faut passer en évolution.

vantaggi della lavorazione nesting classica ma senza più limiti nelle forature orizzontali. Per passare da alte produzioni a "PRODUZIONI JUST IN TIME" è oggi giorno rispondere alle continue tendenze del mercato.

advantages and without limits in the execution of horizontal holes. Switching from high production to cost reduction in order to respond to a continuing changing market.

avantages du nesting et pas de limites dans l'exécution des perçages horizontaux. Pour passer de la production de lots à le "JUST IN TIME", il faut passer en évolution.

- **Catalogo multimediale** potete scannerizzare con il vostro telefono il codice QR o potete cliccare sul codice QR.
- **Multimedia catalog** you can scan the QR code with your phone or you can click on the QR code.
- **Catalogue multimédia** vous pouvez scanner le code QR avec votre téléphone où vous pouvez cliquer sur le code QR.
- **Catalogo multimedia** Podeis escanear con vuestro smartphone el código QR. Podeis hacer clic en el código QR.



### Standard

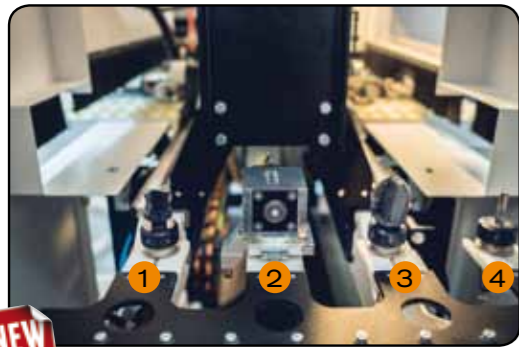

- Cambio utensili a 4 posizioni
- 4 positions tool changer
- Magasin automatique à 4 position

### Optional **PATENTED**



- Vitap free Nesting System per un taglio perfetto all'interno del pannello
- Vitap free Nesting System for perfect cutting inside of the panel
- Vitap free Nesting System pour une exécution de coupe parfait à l'intérieur du panneau

### Optional



- Lamello Clamex P

### Optional



- Fresatura orizzontale
- Horizontal milling
- Fraisage horizontal

### Standard

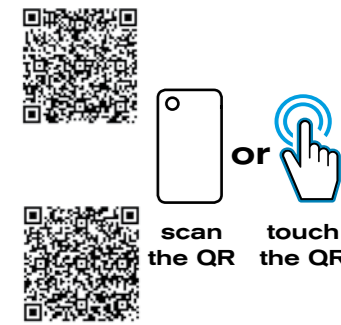
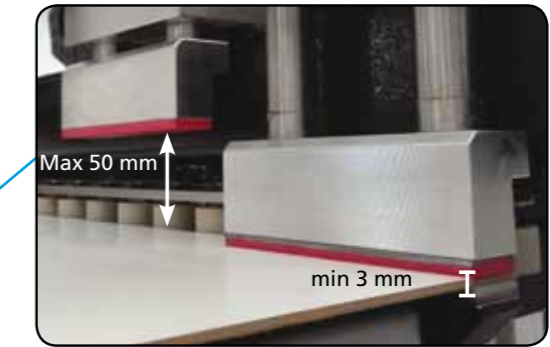

- **D-D-T (Double Dynamic Transport) **PATENTED****

### Standard



- Dispositivo antischeggiatura su 4 lati 0-3 mm
- 4 sides milling device 0-3 mm
- Dispositif anti-éclats sur les 4 côtés 0-3 mm

### Standard

**Vitap Bar Nesting System **PATENTED****

4 min. Including cutting

scan the QR OR touch the QR

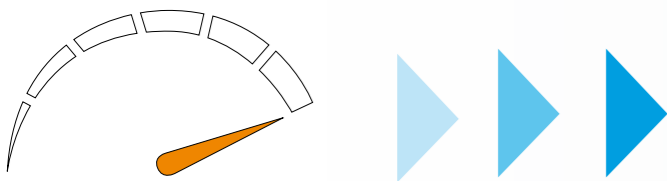

# K2 2.0



## 🇮🇹 DATI TECNICI (standard)

## 🇬🇧 TECHNICAL DATA (standard)

## 🇫🇷 DONNEES TECHNIQUES (standard)

Numero di mandrini indipendenti verticali:	12	Number of vertical independent spindles:	12
Numero di mandrini orizzontali sull'asse X:	(2 + 2)	Number of horizontal spindles on axis X :	(2+2)
Numero di mandrini orizzontali sull'asse Y:	(2 + 2)	Number of horizontal spindle on axis Y:	(2+2)
N° 1 lama:	(ø 100 mm)	N° 1 saw blade unit:	(ø 100 mm)
N° 1 Pantografo:	5 Kw ISO 30 - 12000/24000 giri / min	N° 1 Router head:	5 Kw ISO 30 - 12000/24000 rpm
Max. Spessore del pannello:	50 mm	Max. thickness of the panel:	50 mm
Controllo:	Parametrico completo	Control:	Full Parametric
Peso massimo del pannello:	Kg 80	Max weight of the panel:	Kg 80
Dimensioni max del pannello:	X ∞, Y 1250, Z 50 mm	Max panel size:	X ∞, Y 1250, Z 50 mm
Dimensioni del pannello min:	X 270, Y 150 (70 op.), Z 3 mm	min panel size:	X 270, Y 150 (70 opt.), Z 3 mm
Numero di assi controllati:	3	Number of controlled axes:	3
Velocità di alimentazione del pannello:	25 m / min	Panel feeding speed:	25 m/min
Velocità rotazione dei mandrini:	3600 giri / min	Spindles speed rotation:	3600 rpm
Velocità rotazione della lama:	7000 giri / min	Saw blade speed rotation:	7000 rpm
Pressione d'aria:	7 bar	Air pressure:	7 bar
Diametro aspirazione:	2 x ø 120 mm + 1 x ø 50 mm	Diameter of the dust extraction:	2 x ø 120 mm + 1 x ø 50 mm
Dati aspirazione :	(2700 mc / ora) - (30 m / s)	Suction system data:	(2700 mc / hour) - (30 m/s)
Max prof. di foratura in orizz. su assi X e Y:	X 50mm* - Y 30 mm	Max drilling depth in horiz. on X and Y axis:	5X 50mm* - Y 30 mm
Max profondità di foratura in verticale:	43 mm	Max drilling depth in vertical:	43 mm
Max diametro orizzontale degli utensili:	15 mm	Max horizontal diameter of the tools:	15 mm
Max diametro verticale degli utensili:	35 mm	Max vertical diameter of the tools:	35 mm
Potenza motore testa a forare:	1,7 kw	Motor power drilling head:	1,7 kw
Potenza totale:	7 Kw	Total power:	7 Kw
Consumo aria:	750 nlt / min.	Air consumption:	750 nlt / min.
Dimensioni:	2900x1650x1890 mm	Size:	2900x1650x1890 mm
Peso:	Kg 1310	Weight:	Kg 1310
Norme CE		CE Standards	

Numéro mandrins indépendant verticaux:	12	Numéro mandrins horizontal sur l'axe X:	(2+2)
Numéro mandrins horizontal sur l'axe Y:	(2+2)	Numéro mandrins horizontal sur l'axe Y:	(2+2)
N°1 lame pour exécution de la rénure	(ø 100 mm)	N°1 tete defonçage	5 Kw ISO 30 - 12000/24000 rpm
N°1 tete defonçage	5 Kw ISO 30 - 12000/24000 rpm	Max. épaisseur du panneau:	50 mm
Max. épaisseur du panneau:	50 mm	Commande numérique:	Full Parametric
Commande numérique:	Full Parametric	Max poids di panneau:	kg 80
Max poids di panneau:	kg 80	Dimensions Max du panneau:	X ∞, Y 1250, Z 50 mm
Dimensions Max du panneau:	X ∞, Y 1250, Z 50 mm	Dimensions min du panneau:	X 270, Y 150 (70 opt.), Z 3 mm
Dimensions min du panneau:	X 270, Y 150 (70 opt.), Z 3 mm	Numéro axes contrôlés:	3
Numéro axes contrôlés:	3	Vitesse d'avancement du panneau:	25m/min
Vitesse d'avancement du panneau:	25m/min	Vitesse de rotation des mandrins:	3600 rpm
Vitesse de rotation des mandrins:	3600 rpm	Vitesse de rotation lame:	7000 rpm
Vitesse de rotation lame:	7000 rpm	Pression d'exercice:	7 bar
Pression d'exercice:	7 bar	Diamètre hotte d'aspiration:	2 x ø 120 mm + 1 x ø 50 mm
Diamètre hotte d'aspiration:	2 x ø 120 mm + 1 x ø 50 mm	Données aspiration:	(2700 mc / heure) - (30 m/s)
Données aspiration:	(2700 mc / heure) - (30 m/s)	Max profondeur de perçage horizontal axes X et Y:	X 50mm* - Y 30 mm
Max profondeur de perçage horizontal axes X et Y:	X 50mm* - Y 30 mm	Max profondeur de perçage vertical:	43 mm
Max profondeur de perçage vertical:	43 mm	Max diamètre de la mèche horizontal:	15 mm
Max diamètre de la mèche horizontal:	15 mm	Max diamètre de la mèche vertical:	35 mm
Max diamètre de la mèche vertical:	35 mm	Moteur tete de perçage:	1,7 kw
Moteur tete de perçage:	1,7 kw	Puissance totale:	7 kw
Puissance totale:	7 kw	Air consumption:	750 nlt / min.
Air consumption:	750 nlt / min.	Dimension:	2900x1650x1890 mm
Dimension:	2900x1650x1890 mm	Poids:	kg 1310
Poids:	kg 1310	Normes CE	
Normes CE			

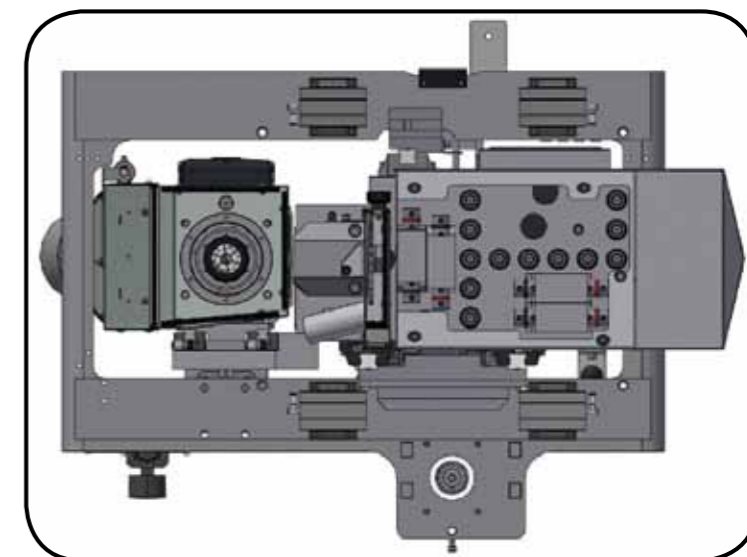

\* X 43 mm con punte standard (ITA)

\* X 43 mm with standard drills bit (EN)

\* X 43 mm avec des mèches standard (FR)

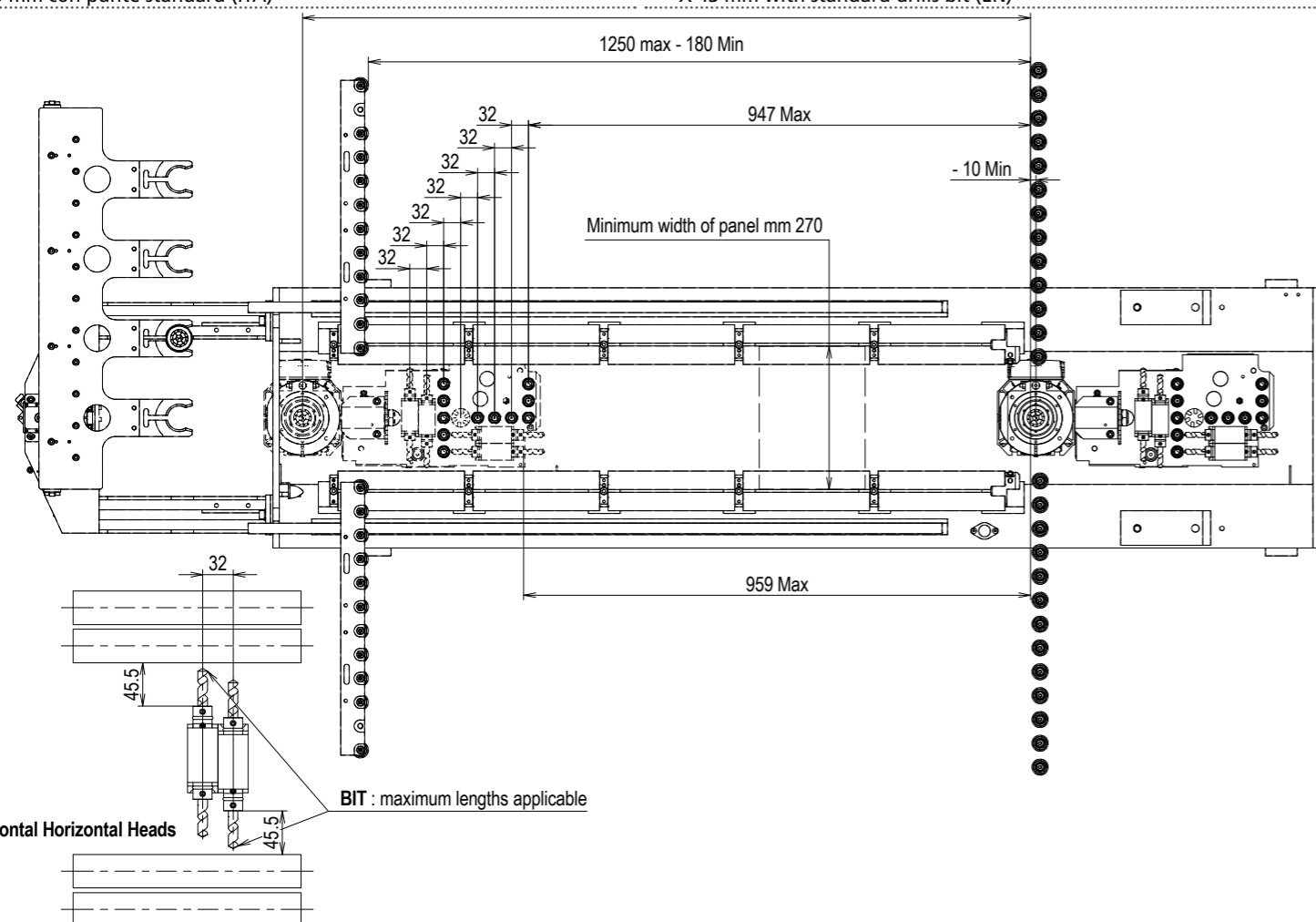

# ▪ Perché scegliere la serie Point ▪ Why choose the Point series ▪ Pourquoi choisir la serie Point



- **Sei una piccola o media impresa?**
- **Are you a small or medium enterprise?**
- **Êtes-vous une petite ou moyenne entreprise?**

- La serie Point è ideale per piccole e medie imprese con budget limitati, ridotte capacità di stoccaggio, pochi impiegati e necessità di movimentare grandi pannelli.
- The Point series is perfect for small to medium size companies which have limited budget, availability of manufacturing and stocking space, few employees, and issues with the handling of large panels.
- La serie Point est indiquée pour : Les PME (petites et moyennes entreprises) qui ont la nécessité de gérer des espaces réduits, des problèmes de personnel (quelques fois 2 ou 3 personnes), des problèmes de stockage et de manipulation des panneaux de grandes dimensions, ceci avec un budget qui doit être bien rationalisé.



- **Sei una grande industria?**
- **Are you a large company?**
- **Êtes-vous une grande industrie?**

- La serie Point è stata progettata per le grandi aziende che necessitano di macchine produttive ed affidabili evitando i costi tipici dei grandi CNC, molti dei quali hanno bisogno di personale altamente specializzato difficilmente reperibile.
- The Point series has been designed and engineered for the large companies that need productive and reliable machines, without the cost and complexity of large CNC, which usually require specialized technicians that might be difficult to find and retain.
- La serie Point a aussi été conçue et pensée pour les grandes Entreprises qui peuvent ainsi obtenir d'énormes avantages de productivité, de fiabilité, et à moindre coûts par rapport à de plus grandes installations parfois trop complexes et qui nécessitent des techniciens très spécialisés (et difficiles à remplacer) ainsi que d'une assistance très coûteuse.



# evolutionary ~~theory~~ facts

# K2 2.0 VS traditional CNC



- COSA DEVI SAPERE SUI CENTRI DI LAVORO TRADIZIONALI  
**i loro svantaggi sono i nostri punti di forza...**
- WHAT YOU NEED TO KNOW ABOUT TRADITIONAL CNC WORK CENTERS  
**Their weakness is our strength...**
- CE QUE VOUS DEVEZ SAVOIR SUR LES CENTRES DE TRAVAIL À CNC TRADITIONNELS  
**Leurs inconvénients sont nos point forts...**



traditional CNC

K2 2.0

<p>DIMENSIONI SIZE TAILLE</p>	<ul style="list-style-type: none"> <li>• Dimensioni imponenti, richiedono spazi adeguati</li> <li>• Huge size, need appropriate space</li> <li>• Dimensions imposantes, nécessitent un espace suffisant</li> </ul>	<ul style="list-style-type: none"> <li>• Compatta e leggera: occupa solo 5 m<sup>2</sup></li> <li>• Compact and light: it takes only 5 sqm</li> <li>• Compact et léger: elle n'occupe que 5 m<sup>2</sup></li> </ul>
<p>INSTALLAZIONE INSTALLATION INSTALLATION</p>	<ul style="list-style-type: none"> <li>• Fasi di trasporto e installazione lunghe e complesse</li> <li>• Transport and installation phases are complex</li> <li>• Phases de transport et d'installation longues et complexes</li> </ul>	<ul style="list-style-type: none"> <li>• Collegi la macchina alla corrente ed è subito operativa</li> <li>• Connect to the electrical system and the machine is ready</li> <li>• Connectez la machine au cablage et elle est immédiatement opérationnelle</li> </ul>
<p>ASPIRAZIONE SUCTION SYSTEMS SYSTÈMES D'ASPIRATION</p>	<ul style="list-style-type: none"> <li>• Alti costi per impianti di aspirazione adeguati (5-6000 m<sup>3</sup>/h)</li> <li>• High costs for adequate suction systems (5-6000 m<sup>3</sup>/h)</li> <li>• Coûts élevés pour des systèmes d'aspiration adéquats (5-6000 m<sup>3</sup>/h)</li> </ul>	<ul style="list-style-type: none"> <li>• Necessità di impianto di aspirazione modesti (2000 m<sup>3</sup>/ora)</li> <li>• Small suction system required (2000 m<sup>3</sup>/hour)</li> <li>• Nécessite d'un système d'aspiration modeste (2000 m<sup>3</sup> / h)</li> </ul>
<p>ATTREZZAGGIO SET-UP PRÉPARATION</p>	<ul style="list-style-type: none"> <li>• Prolungati tempi di attrezzaggio macchina</li> <li>• Setting up the machine and components take quite a long time</li> <li>• Longue phase de préparation de la machine et des différents composants</li> </ul>	<ul style="list-style-type: none"> <li>• Tempi di attrezzaggio ridotti</li> <li>• Ready in few minutes: just put the tools</li> <li>• Il suffit de mettre les outils et c'est prêt</li> </ul>
<p>VENTOSE SUCKERS VENTOUSES</p>	<ul style="list-style-type: none"> <li>• Elevati costi magazzino ventose</li> <li>• High inventory suckers cost</li> <li>• L'utilisation de ventouses est obligatoire et aussi les coûts des stockage est très cher</li> </ul>	<ul style="list-style-type: none"> <li>• Non c'è bisogno di ventose</li> <li>• It doesn't need suckers</li> <li>• Pas besoin de ventouses</li> </ul>
<p>MANIPOLAZIONE HANDLING MANIPULATION</p>	<ul style="list-style-type: none"> <li>• Manipolazione complicata e faticosa</li> <li>• More operators are needed at least for panel handling</li> <li>• Il faut au moins plus d'opérateurs pour la manipulation des panneaux</li> </ul>	<ul style="list-style-type: none"> <li>• Nella filosofia Vitap BAR NESTING: manipolazione più agevole</li> <li>• Vitap BAR NESTING philosophy: one person is enough to do the job</li> <li>• Dans la philosophie Vitap BAR NESTING: un seul opérateur suffit pour le travail</li> </ul>
<p>NESTING HORIZONTAL DRILLING PERÇAGE HORIZONTAL</p>	<ul style="list-style-type: none"> <li>• Grandi limiti per la foratura orizzontale</li> <li>• Limited horizontal drilling</li> <li>• Perçage horizontal limité</li> </ul>	<ul style="list-style-type: none"> <li>• Nella filosofia Vitap BAR NESTING: nessun limite di foratura orizzontale</li> <li>• Vitap BAR NESTING philosophy: no limits in horizontal drilling</li> <li>• Dans la philosophie Vitap BAR NESTING: aucune limite de perçage horizontal</li> </ul>
<p>COSTI DI GESTIONE OPERATING COSTS COÛTS DE GESTION</p>	<ul style="list-style-type: none"> <li>• Consumi elevati ed alti costi elettro-pneumatici</li> <li>• High consumption and high electro-pneumatic costs</li> <li>• Consommation élevée et coûts électropneumatiques élevés</li> </ul>	<ul style="list-style-type: none"> <li>• A basso consumo energetico</li> <li>• Low energy consumption</li> <li>• Faible consommation d'énergie</li> </ul>
<p>MANUTENZIONE MAINTENANCE MAINTENANCE</p>	<ul style="list-style-type: none"> <li>• Tempi e costi di manutenzione elevati</li> <li>• High maintenance times and costs</li> <li>• Temps et coûts de maintenance élevés</li> </ul>	<ul style="list-style-type: none"> <li>• Non richiede particolare manutenzione</li> <li>• No particular maintenance needed</li> <li>• Il ne nécessite pas d'entretien particulier</li> </ul>

La foratura orizzontale nel Nesting tradizionale è un grande limite

Horizontal drilling in traditional Nesting is a big limit

Le perçage horizontal dans le Nesting traditionnelle est une grande limite

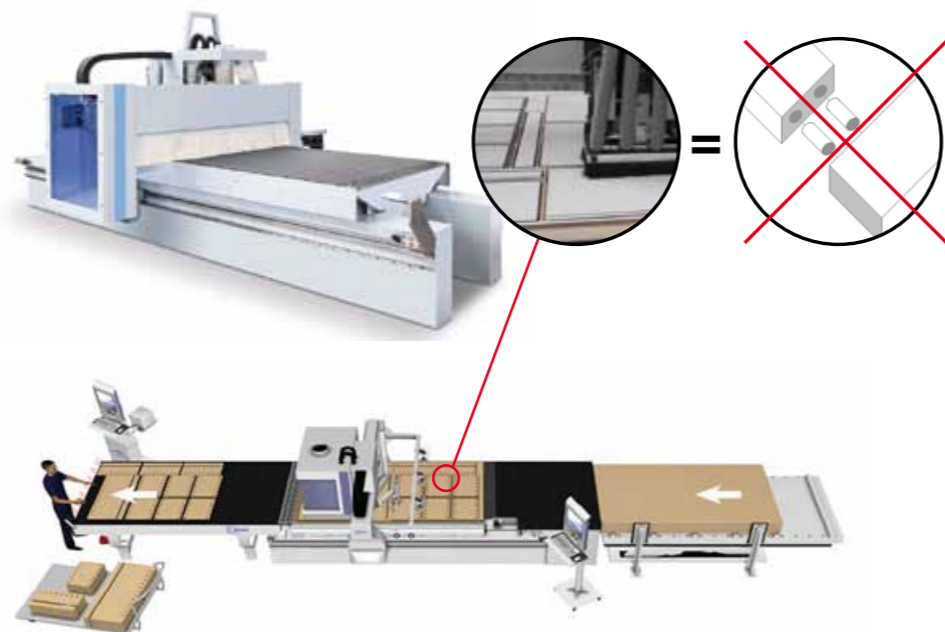

### Vitap Bar Nesting System PATENTED

- I SOLI A DARTI LA SOLUZIONE
- THE ONLY ONE TO GIVE YOU THE SOLUTION
- LES SEULS À VOUS DONNER LA SOLUTION



**4 min.**  
Including cutting



CNC Tradizionali:  
Attrezzaggio & Ventose = molteplici manipolazioni

Traditional CNC:  
Setup & Suckers = multiple manipulations

CNC traditionnel:  
Preparation & Ventouses = manipulations multiples

- Per avere le idee più chiare... vedere il video
- To get clearer ideas... see the video
- Pour avoir les idées plus claires... voir la video





# K2 2.0



# Galileo



# Point2

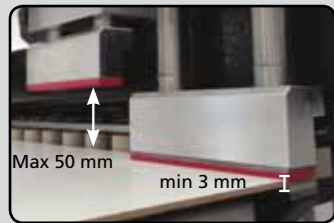

**D-D-T (Double Dynamic Transport)**

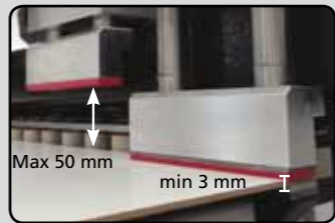

**D-D-T (Double Dynamic Transport)**



Max panel size: X ∞ ,Y 1250, Z 50 mm  
min panel size: X 270,Y 150 (70 opt.), Z 3 mm

Max panel size: X ∞ ,Y 920, Z 50 mm  
min panel size: X 270,Y 150 (70 opt.), Z 3 mm

Max panel size: X ∞ ,Y 920, Z 50 mm  
min panel size: X 270,Y 150 (70 opt.), Z 10 mm

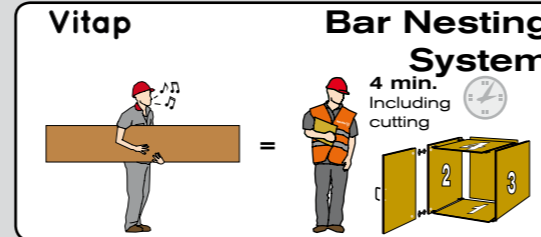
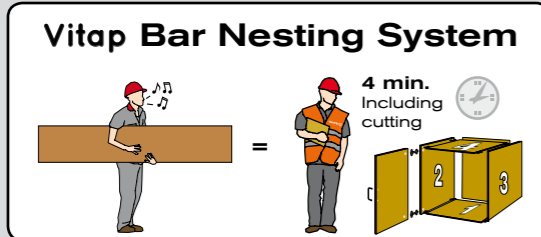

- Dispositivo antischeggiatura su 4 lati 0-3 mm
- 4 sides milling device 0-3 mm
- Dispositif anti-éclats sur les 4 côtés 0-3 mm

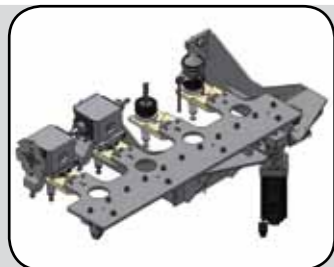

- Cambio utensili a 4 posizioni
- 4 positions tool changer
- Magasin automatique à 4 position

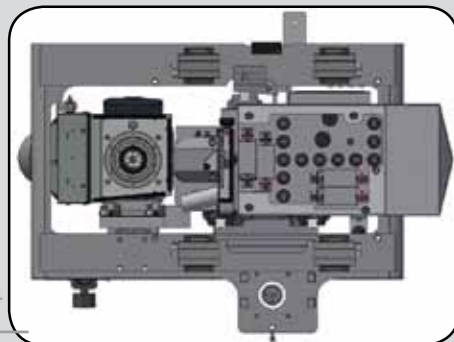

Vertical n°12  
Horizontal X axis n° (2+2)  
Horizontal Y axis n° (2+2)  
n°1 saw blade  
n°1 router 5 kw ISO 30

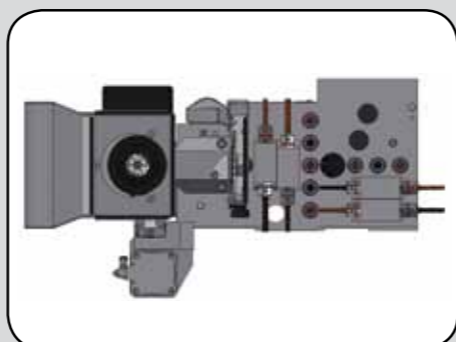

Standard **Galileo 1 - 2 - 3**  
Vertical n°9  
Horizontal X axis n° (2+2)  
Horizontal Y axis n° (2+2)  
n°1 saw blade

<b>Galileo 2</b>	<b>Galileo 3</b>
Routing unit	Routing unit
ER 32 - 3,6 KW (Rpm 24000)	ISO 30 - 5 KW (Rpm 24000)

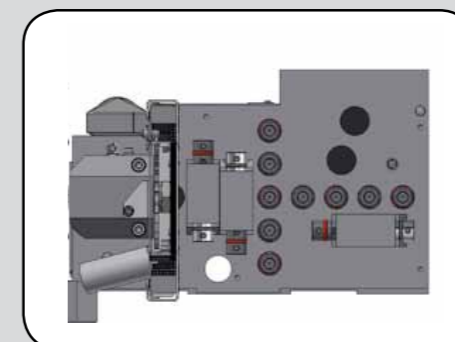

Vertical n°9  
Horizontal X axis n° (2+2)  
Horizontal Y axis n° (1+1)  
n°1 saw blade



# Automation for our compact CNC Machines

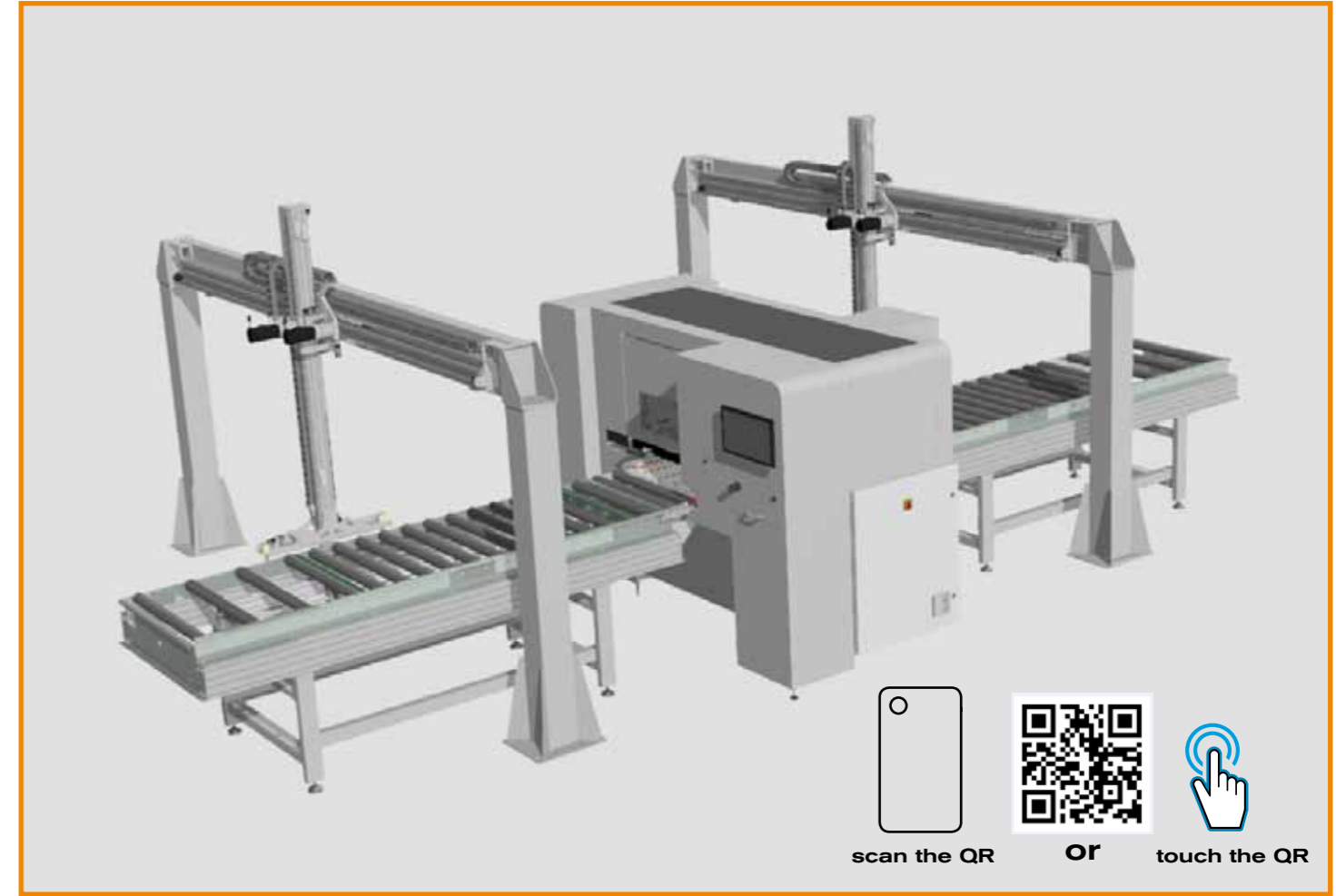
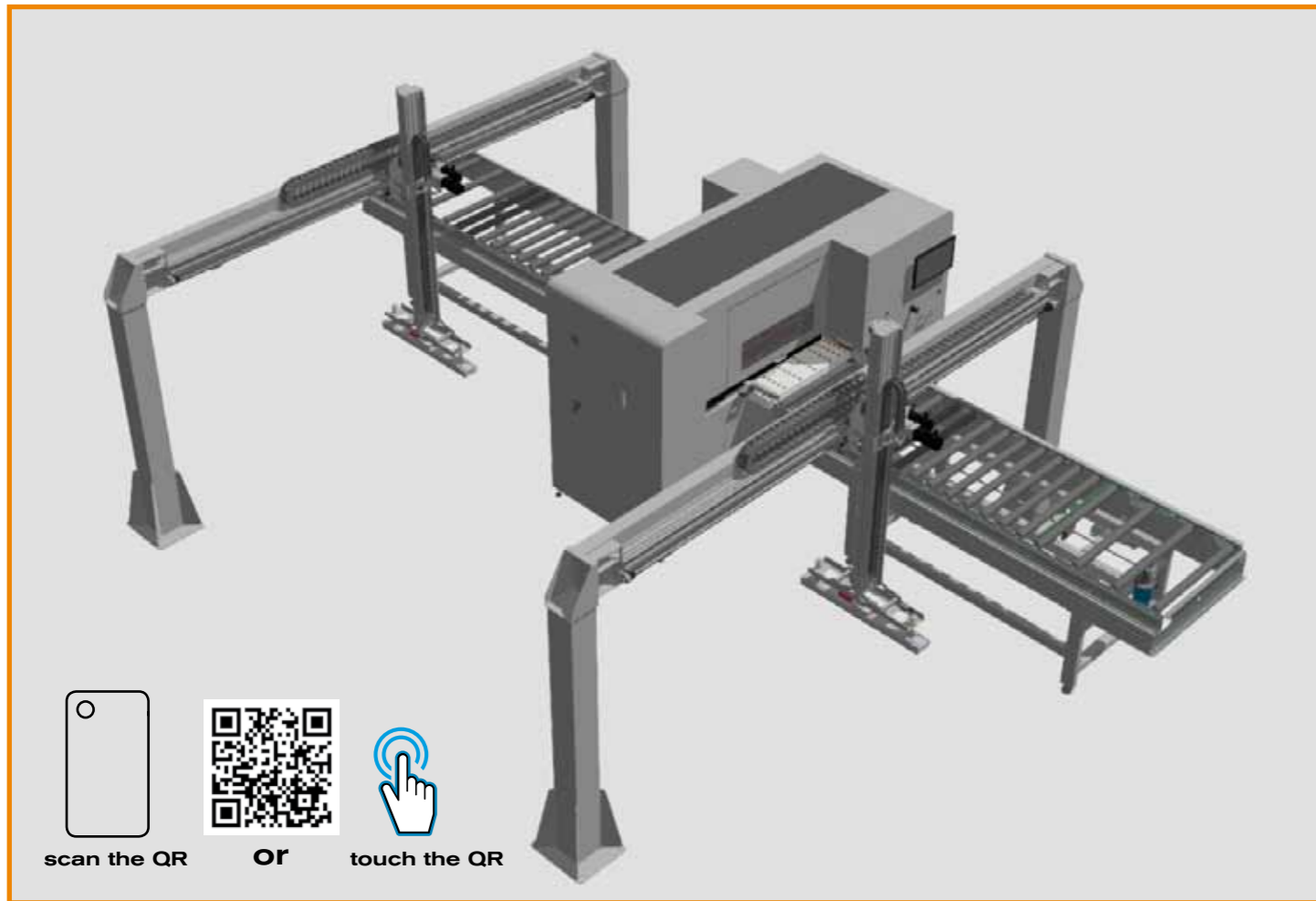

- Dai bracci robotici dei supermercati online più evoluti, che vanno a prelevare dagli scaffali gli articoli difficilmente raggiungibili, fino agli elettrodomestici, che ci aiutano nelle faccende domestiche, le tecnologie dell'automazione sono ormai una presenza costante nella nostra quotidianità. Questi tipi di automazione applicati all'interno di una fabbrica o di un'industria hanno consentito un sensibile miglioramento nella catena produttiva. Anche Vitap è lieta di presentare un comparto dedicato all'automazione che va ad integrarsi perfettamente alla flotta dei Compatti Centri di Lavoro a CN Serie Point K2 e Serie ACOUSTIC, dando vita a vere e proprie CELLULE PRODUTTIVE. La filosofia di Vitap è di accompagnare i propri clienti in un percorso evolutivo partendo da una macchina compatta CN altamente evoluta per poi renderla totalmente autonoma grazie alla sua automazione sartoriale.

- From the most sophisticated antropomorphic robots in the warehouses of the great distribution giants, to the basic house hardware, handling equipments are helping nowadays to creat efficiency and cost effective operations. These handling systems have contributed to make factories more productive and efficient too. Vitap is glad to present a new department dedicated to automation which is interconnected to the fleet of compact CNC working centers of K2 and Acoustic series, allowing the creation of productive cells. Vitap philosophy aims to evolve, together her customers, from stand alone working centers to a self feeding and stacking working cell thanks to a tailored automation system.

- À partir des bras robotiques des supermarchés en ligne les plus avancés, qu'ils vont à la recherche des articles difficiles à atteindre aux étagères, en passant par les appareils, qui nous aident dans les tâches ménagères, les technologies d'automatisation sont désormais présentes de manière constante dans notre vie quotidienne. Ces types d'automatisation appliqués dans une usine ou une industrie ont permis une amélioration significative de la chaîne de production. Vitap est également heureux de présenter un secteur dédié à l'automatisation qui s'intègre parfaitement à la flotte de centres d'usinage Compact Point K2 CN et ACOUSTIC, donnant vie à de véritables CELLULES DE PRODUCTION. La philosophie de Vitap est d'accompagner ses clients sur une trajectoire évolutive, en commençant par une machine CN compacte hautement évoluée, puis en la rendant totalement indépendante grâce à son automatisation sartorial

- Desde los brazos robóticos de los supermercados en línea más avanzados, que llevan los artículos difíciles de alcanzar desde los estantes, hasta los electrodomésticos, que nos ayudan con las tareas domésticas, las tecnologías de automatización ahora son una presencia constante en nuestra vida diaria. Estos tipos de automatización aplicados dentro de una fábrica o una industria han permitido una mejora significativa en la cadena de producción. Vitap también se complace en presentar un sector dedicado a la automatización que se integra perfectamente con la flota de centros de mecanizado de la serie Compact Point K2 NC y ACOUSTIC, dando vida a las CÉLULAS DE PRODUCCIÓN reales. La filosofía de Vitap es acompañar a sus clientes en un camino evolutivo a partir de una máquina CN compacta altamente evolucionada y luego hacerlo totalmente independiente gracias a su automatización sartorial.



 **Vitap**  
Create Smarter



Machines for  
processing  
**Wood**

Machines for  
processing  
**Advanced  
Materials**

Multimedia catalog

scan the QR code



or

touch the QR code



# Automation and CNC Boring Center K2 2.0

- Dati tecnici ed immagini non sono impegnativi. Il costruttore si riserva il diritto di apportare eventuali modifiche senza preavviso.
- Technical details and pictures are only indicative. The manufacturer reserves the right to carry out modifications without prior notice.
- Les données techniques et les photos n'engagent pas le constructeur qui se réserve le droit de les modifier sans préavis.
- Technische Daten und Bilder in diesem Prospekt dienen nur der allgemeinen Information. Der Hersteller behält sich Änderungen, ohne Ankündigung, vor.
- Datos técnicos y de imágenes no son desafiante. El fabricante se reserva el derecho de hacer eventuales modificaciones sin aviso.

*... manufactured in Italy*



Vitap.it

Via Pisana, 149 - 53036 Poggibonsi (SI) - Italy • Phone (+39) 0577 987511

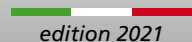

edition 2021